

**GRAPHIC PANELS PREPARATION
FOR CLEVER FRAME SYSTEM**

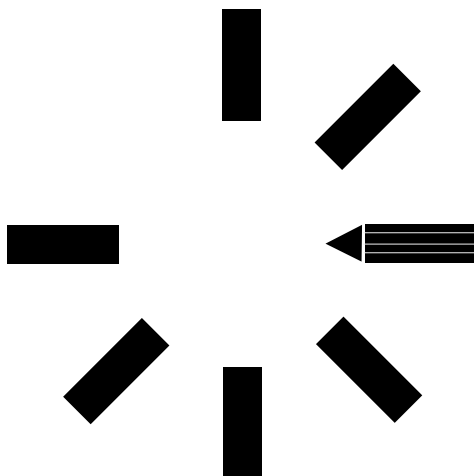

CONTENTS

- 1. HOW TO PROVIDE US PRINT FILES? / PAGE 1.**
- 2. HOW TO PREPARE GRAPHIC FILES / FILE FORMATS? / PAGE 5.**
- 3. PANEL GRAPHICS for PROMO1 **start**, PROMO1 **plus** / PAGE 6.**
- 4. PANEL GRAPHICS for PROMO1 **mini** / PAGE 7.**
- 5. GRAPHICS AND POSITIONING OF THE SHELVES / PAGE 8.**
- 6. GRAPHICS AND POSITIONING OF THE TV / PAGE 9.**

1. HOW TO PROVIDE US PRINT FILES?

On the given order sent by email, CF shares link to our Clever Frame Cloud Service.

To proceed the order within the agreed time, please pay attention to maximum date of delivery of the graphics files, which will be shared with you by our sales representative. If you have not received an e-mail or the link is not active, please contact us..

2. CLICKING ON THE LINK TRANSFERS YOU TO CLEVER CLOUD WEBSITE.

3. THE FOLDER IN WHICH FILES MUST BE PLACED HAS THE ORDER NUMBER AND THE COMPANY NAME.

4. FILES CAN „DRAG AND DROP” FORM YOUR COMPUTER COMPUTER OR ADDED BY „+” BUTTON

*5. IF YOU COOPERATE DIRECTLY WITH ONE OF OUR OFFICIAL INTERNATIONAL PARTNERS PLEASE FOLLOW INSTRUCTIONS PROVIDED BY THE PARTY

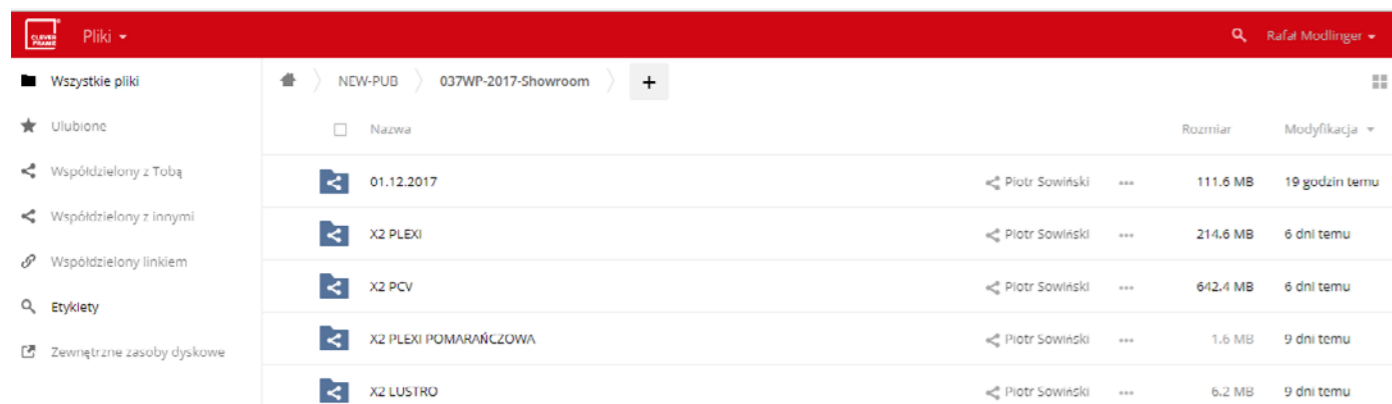

2. HOW TO PREPARE GRAPHIC FILES / FILE FORMATS?

1. FILES SPECIFICATION FOR DIGITAL PRINTING

- TIFF FILE FORMAT
- 120 DPI
- CMYK COLOURS FORMATS
- FLATTENED FILES - NO LAYERS
- LZW COMPRESSION
- DIMENSION IN 1:1 SCALE OF CF STAND
- WITHOUT BLEED

2. FILES PARTITION

- FILES SHOULD BE PREPARED FOR ENTIRE WALLS AND ELEMENTS → SECTION NR 3 AND 4
- DO NOT PLACE IMPORTANT GRAPHIC ELEMENTS ON FRAMES / PANELS INTERSECTIONS → SECURE
- DISTANCE IS 10MM FROM THE EDGES
- FILES SHOULD BE PREPARED WITHOUT BLEED DIVISIONS, CUTTING MARKERS ETC.

3. GRAPHIC PANELS PREPARATION SUPPORT

Any doubts or questions? Write to us:

office@cleverframe.com

or contact your dedicated sales representative.

4. FILES SHOULD BE PREPARED WITHOUT DIVISIONS, CUTTING MARKERS ETC.

We ask for a thorough checking of the contents of the graphic files, as we do not take responsibility for incorrectly prepared graphic files. We ask to pay the utmost attention to typos, names, texts, size of the logotypes, protective field distances from the panel's rims and not to place important graphic elements on the crossings of the graphic panels.

3.

GRAPHICS FOR PROMO1 **START** AND PROMO1 **PLUS** PANELS

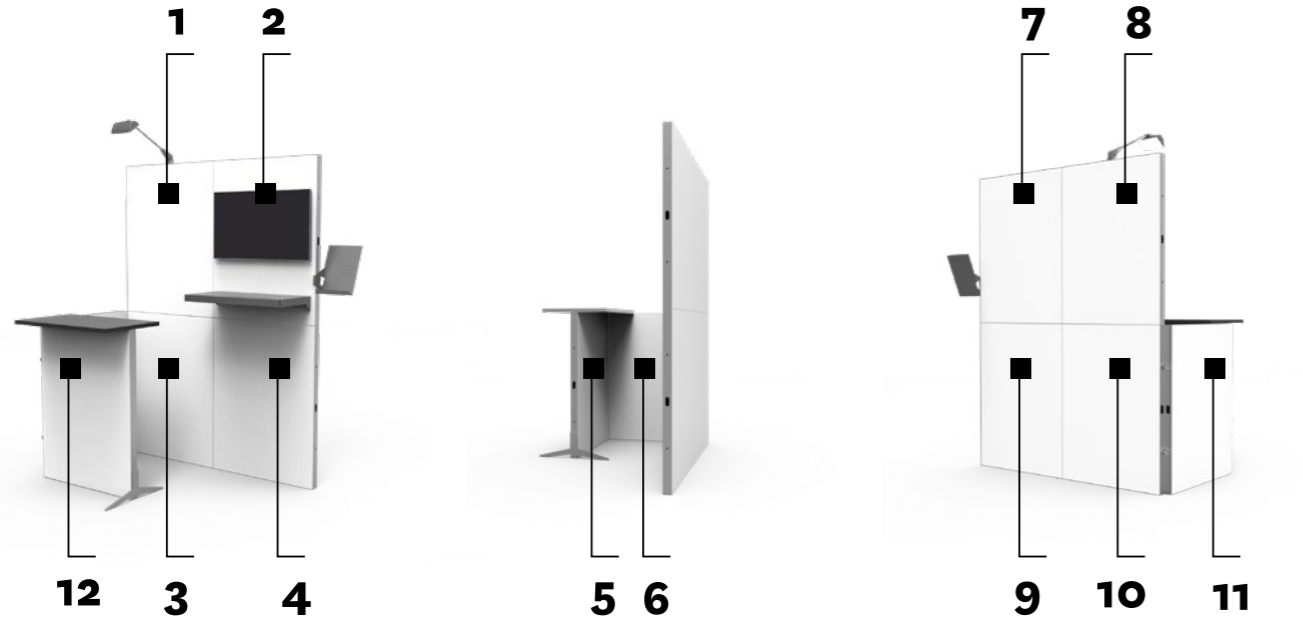

D1
100 x 75 cm

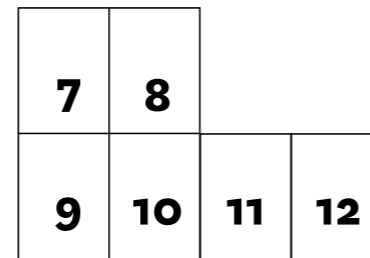
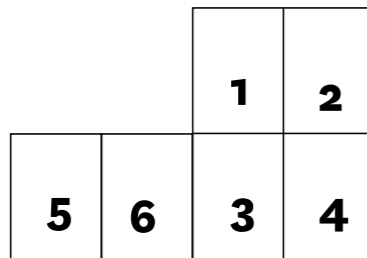

4.

GRAPHICS FOR **MINI** RPOMO1 PANELS

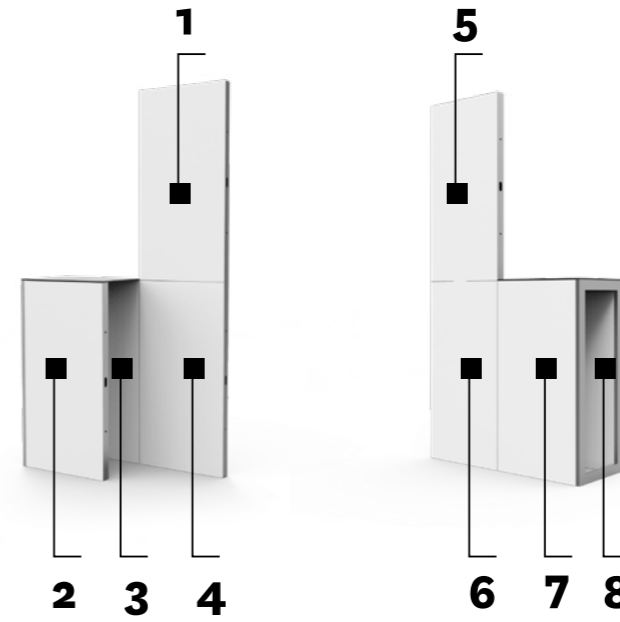

DC1.2
100 x 50 cm

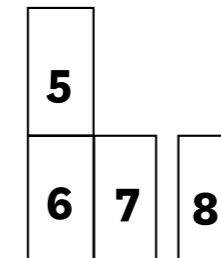
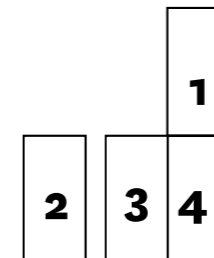

5.

GRAPHICS AND POSITIONING OF CLEVER FRAME® SHELVES

Two rectangular holes, size 8 x 89 mm are cut in the panels to assemble the shelf. Given heights show the distance between the plane of the shelf and the bottom edge of the frame.

FRAME D1/ 100x75 cm

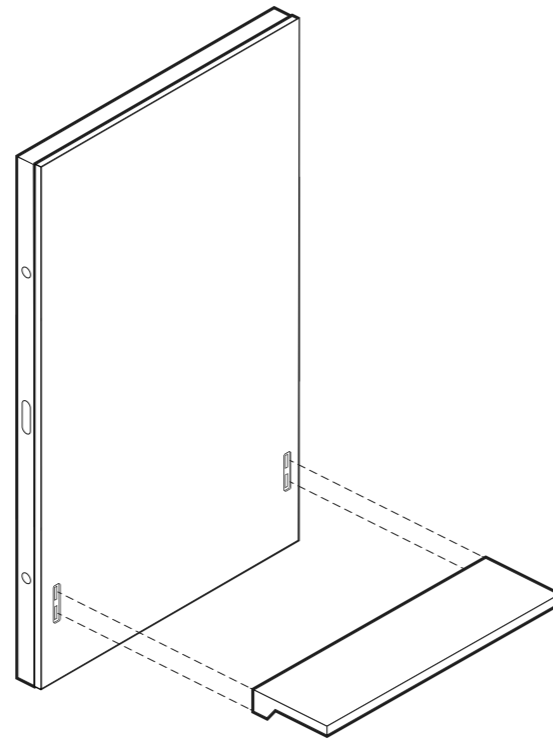
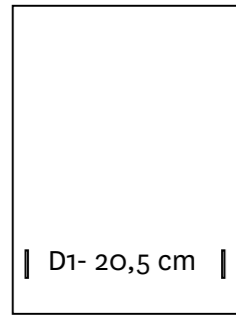

6.

GRAPHICS AND POSITIONING OF THE TV HOLDER

The cut for the TV set is always centrally located, it depends on the size of the TV.

< 42"

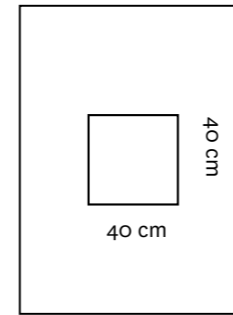

> 42"

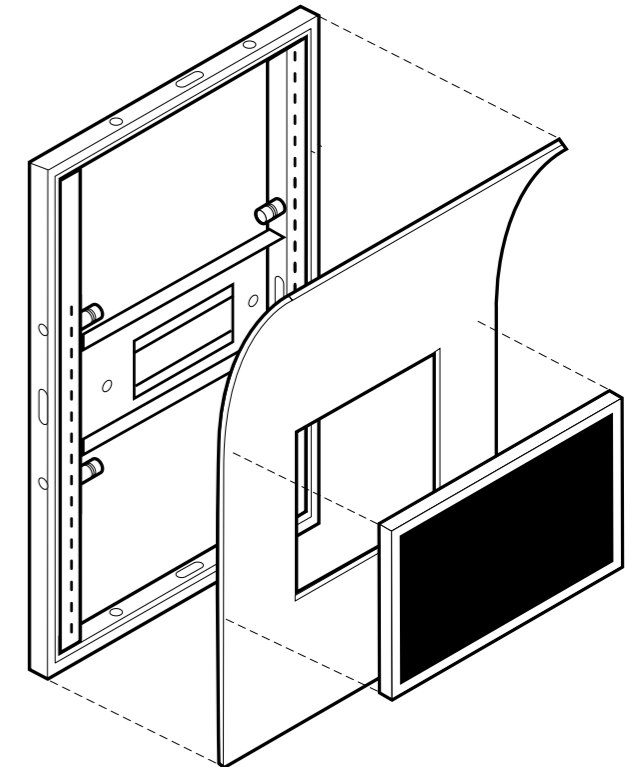
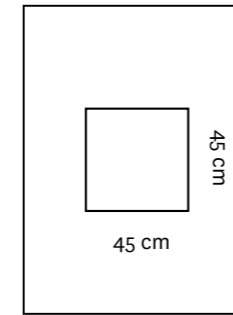

**GRAPHIC PANELS PREPARATION
FOR CLEVER FRAME SYSTEM**

